

Stonewell Egress Window Well Installation Instructions



Stonewell Egress Window Well
WW-44430 - Granite



Stonewell Egress Window Well
WW-44440 - Sandstone
(Shown with optional cover*)

*Clear Cover sold separately – WW-44450

STEP 1

Measure and mark the center of the window. (see figure B)

Measure and mark two lines on each side of the window at the dimensions shown. (see figure B)

Position the edges of the egress well flanges along and within these vertical lines.

NOTE: If proper dimensions are not followed as stated in figure B, cover will not fit properly.

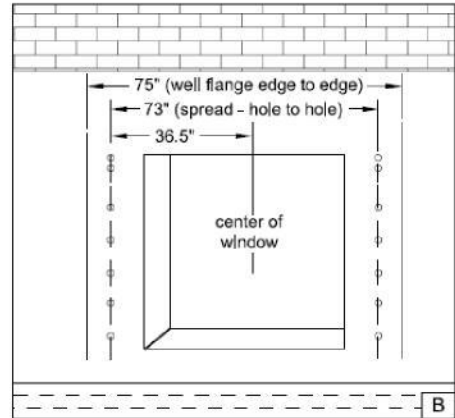

STEP 2

Install using 3/8" x 2-1/2" or larger wedge anchors or Tapcon screws (not included) into the pre-formed hole locations on each flange.

MUST USE A FENDER WASHER (not included) on the outside of the egress flange with each wedge anchor or Tapcon screw.

Install by working from top of each flange to bottom of flange. (See figure C)

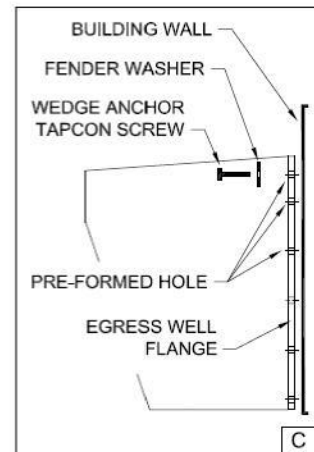

WW-44180 Stonewell/Modular Installation Kit (NOT INCLUDED – Can be purchased separately.)

(1) Drain Cap



(1) Power Fastener
Wedge Drill Bit



(18) Fender Washers



(18) 3/8"x 2-1/2"
Concrete Anchor Bolts



(2) Mounting Brackets



Drainage & Backfill Procedures

Before Backfilling

- When installing the window well, be sure the window well is between 1 to 4 inches above the final grade.
- The window well should be mounted flush against the foundation wall and caulked creating a sealed, water tight fit.
- Drainage is required. If a perimeter drainage system exist tie into this system by means of a 6" capped pipe extension up from the drain line to the base of the well. (Drainage components not supplied.) If no existing system exists an area below the wall should be excavated to the top of the footing and filled with pea stone or clean free-draining rock or else make provisions to direct drainage away from the egress to well drained soil.
- Attach pipe to concrete wall with metal strapping.
- Gutter down spouts should be a minimum of 8 to 10 feet from the window well or at least 10 feet away from the foundation wall and should be directed away from window well with rigid or flexible pipe.

Backfilling Procedures

- Use pea gravel or 3/4 inch or smaller free-draining rock, around the well stopping approximately 1 foot down from the top of the window well. Backfilling by hand, start at the farthest area from the foundation, evenly distributing the stone as you fill. NOTE: This creates a needed backfill barrier around the outer perimeter of the window well preventing the soil from grabbing the well and damaging it.
- The top 6 inches of window well perimeter can then be backfilled with topsoil to final grade. Slope final grade away from egress in all directions.
- By following these backfilling instructions it promotes maximum water drainage and reduces backfill pressure against the window well.

Warning: Wells could be permanently damaged by contact with heavy excavation equipment and/or not following instructions for the backfilling procedure.

